

PROJECT NO.	SHEET NO.	TOTAL SHEETS
13CR.10611.13, 13CR.20611.11	1	

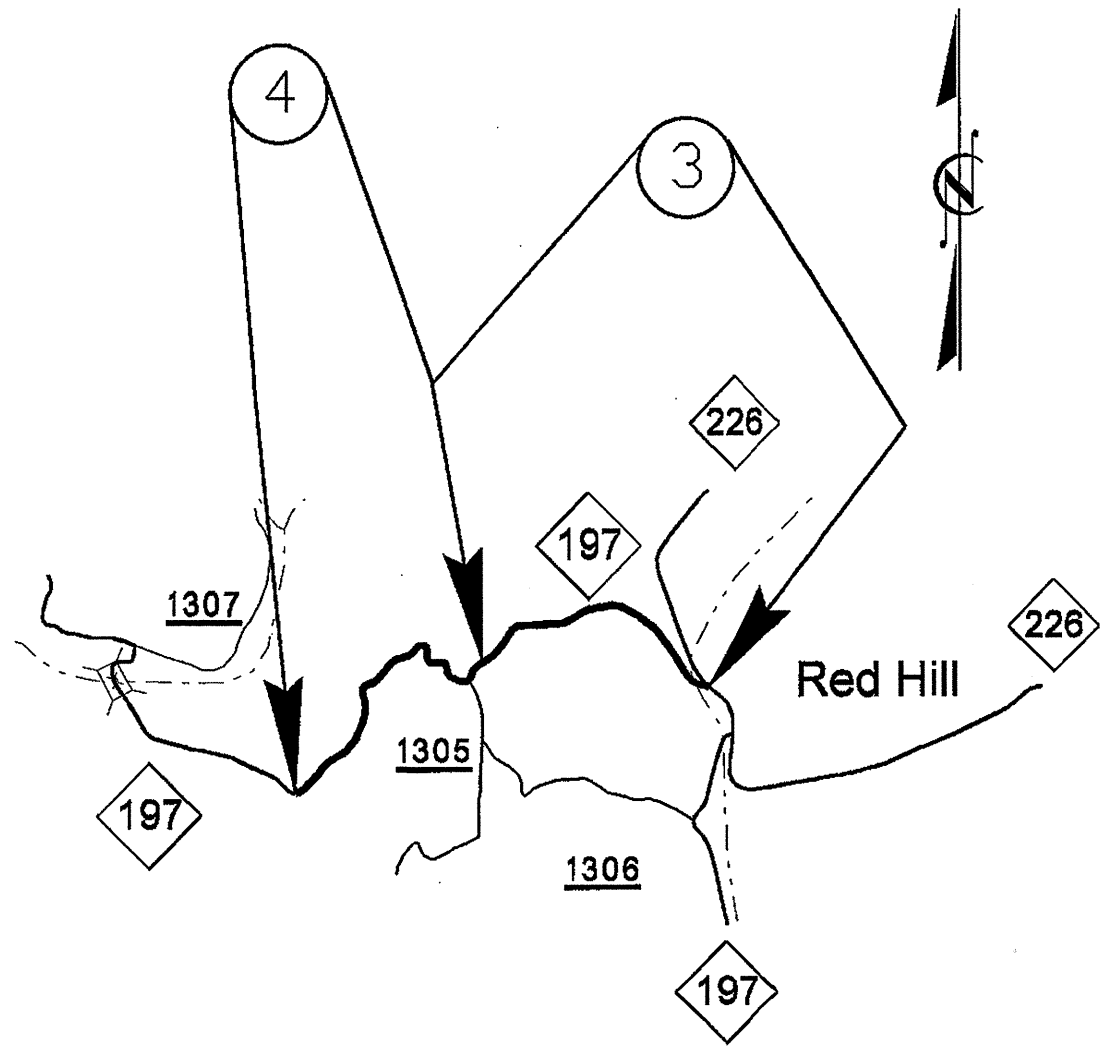

MITCHELL COUNTY

PROJECT NO.	SHEET NO.	TOTAL SHEETS
13CR.10611.13, 13CR.20611.11	2	

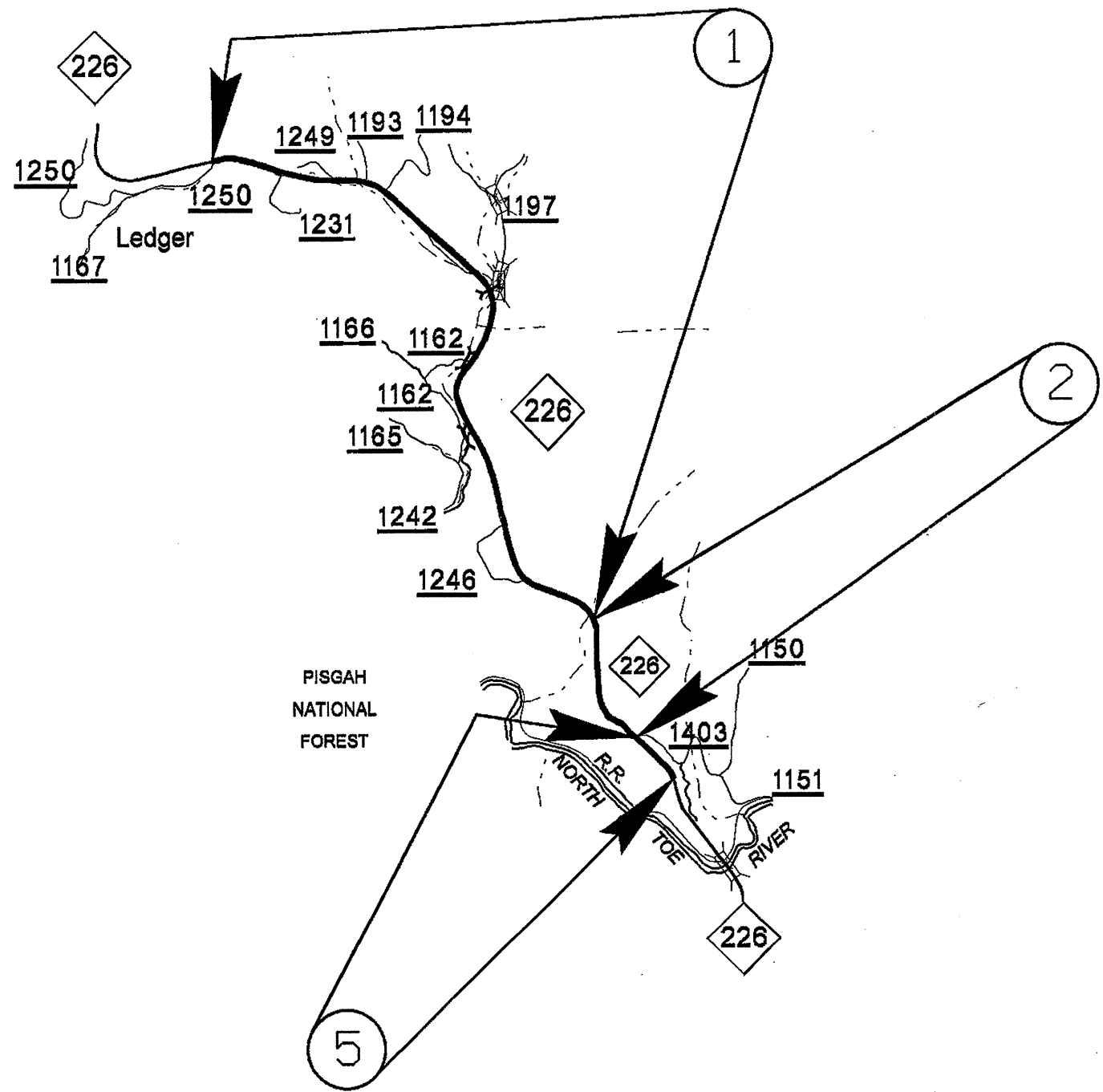
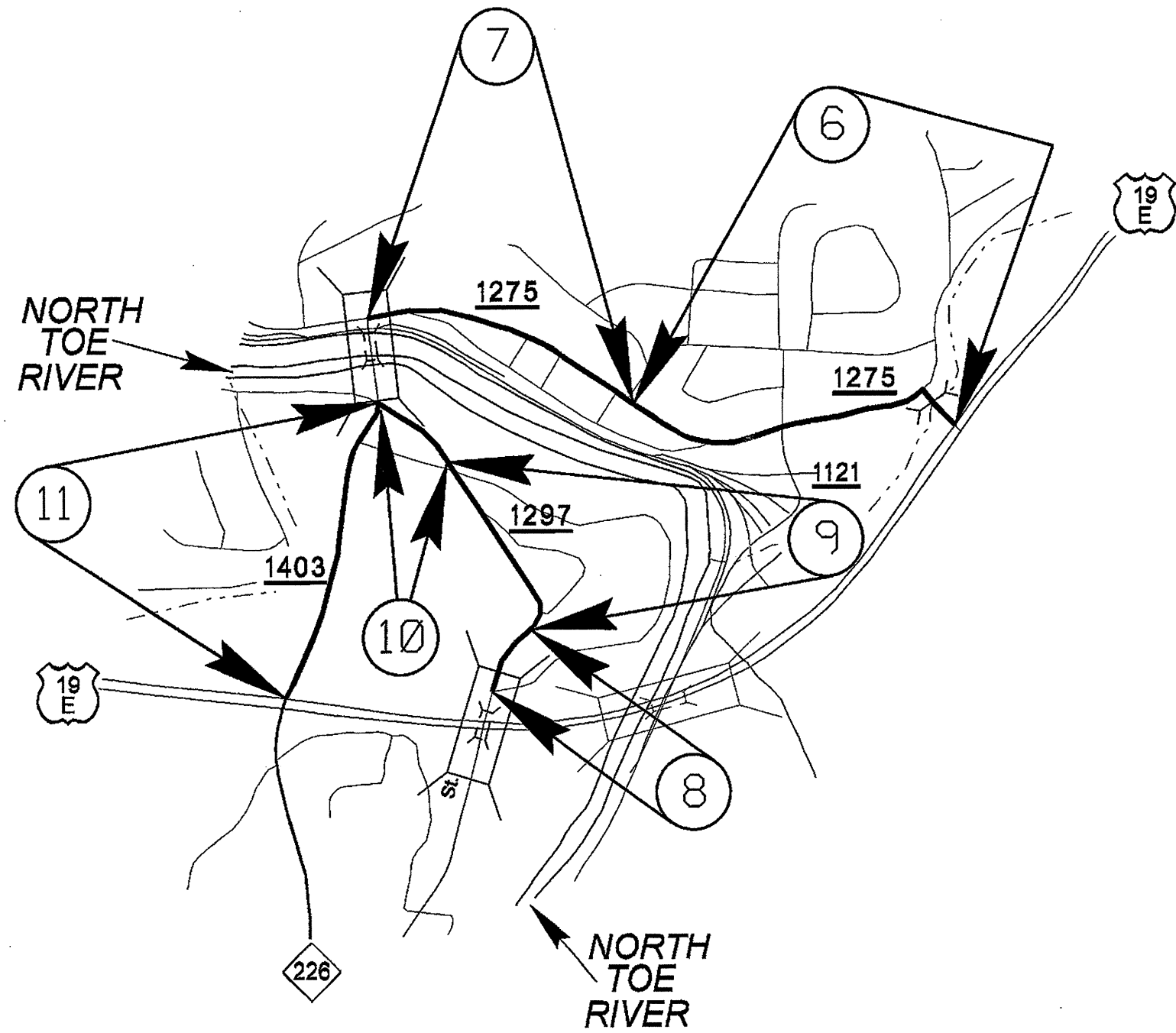

MITCHELL COUNTY

PROJECT NO.	SHEET NO.	TOTAL SHEETS
13CR.10611.13, 13CR.20611.11	3	

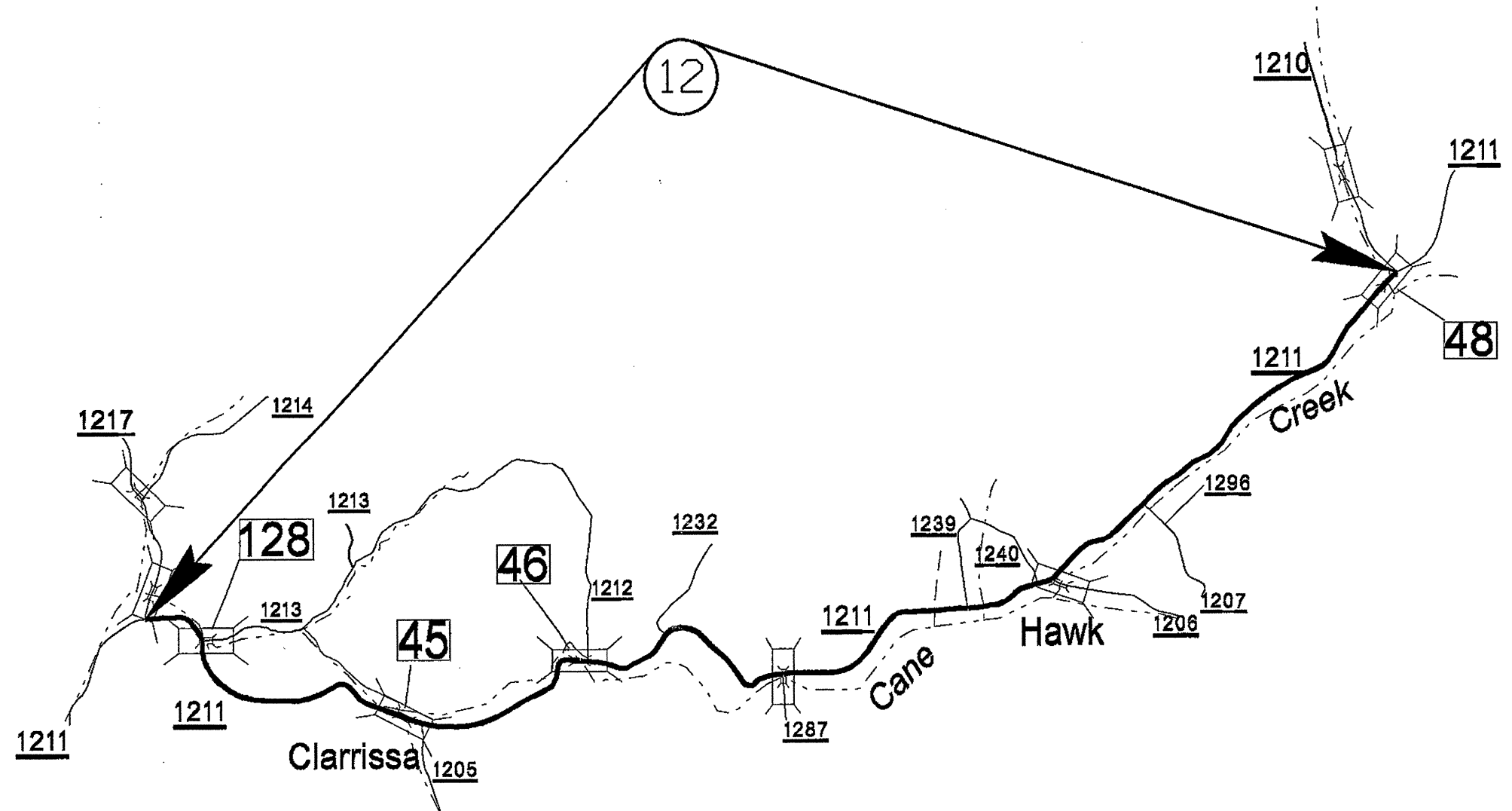

MITCHELL COUNTY

PROJECT NO.	SHEET NO.	TOTAL SHEETS
13CR.10611.13, 13CR.20611.11	4	

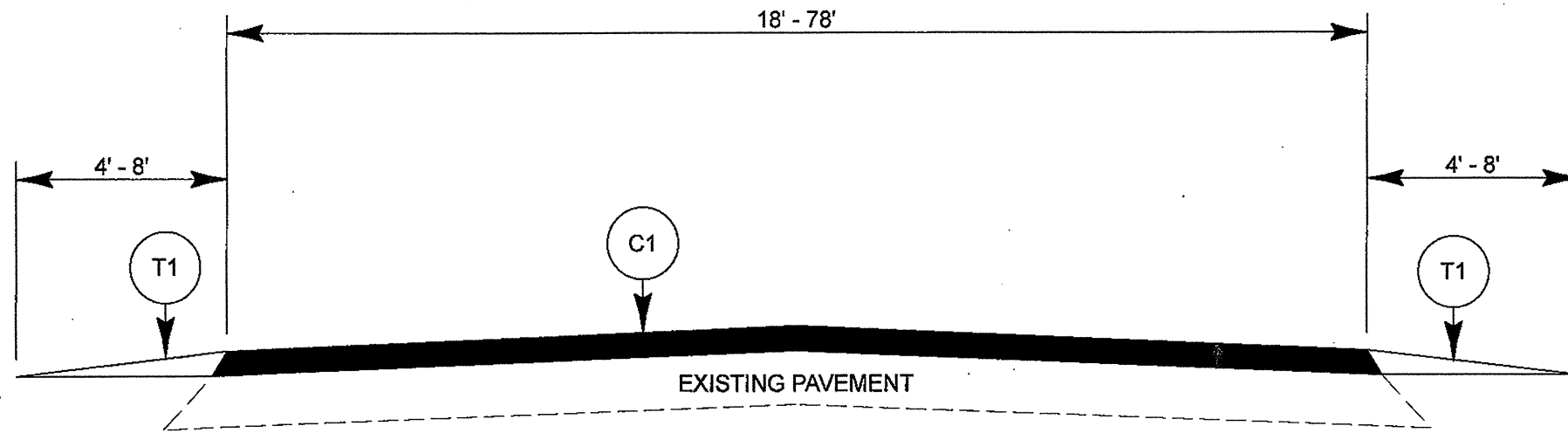

TYPICAL SECTION NO. 1

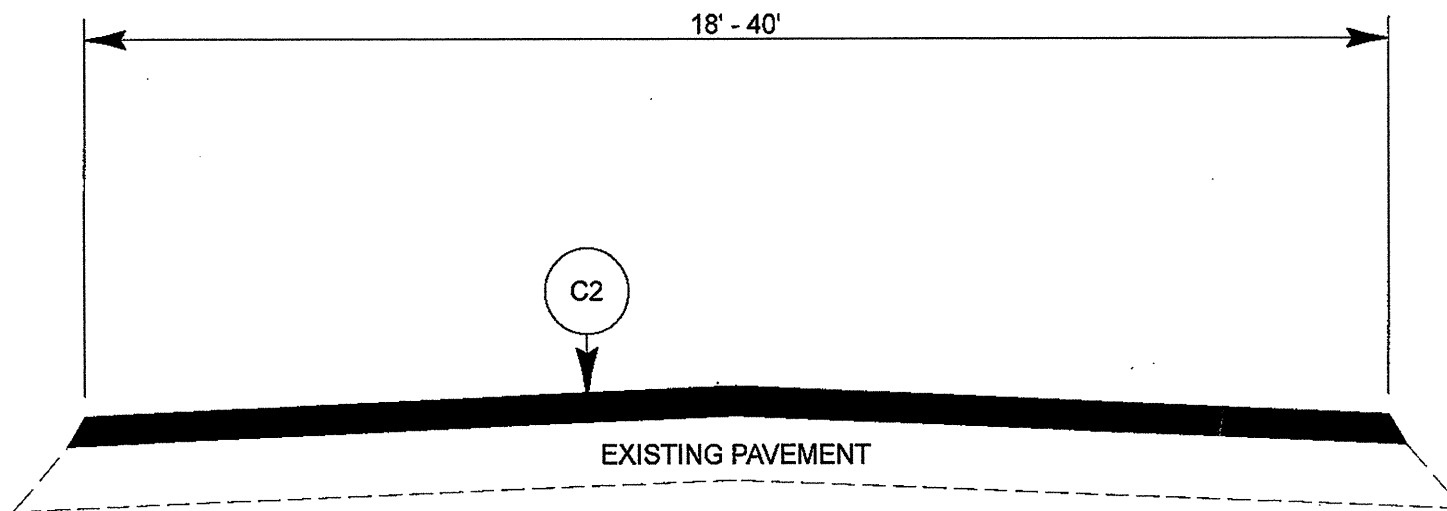
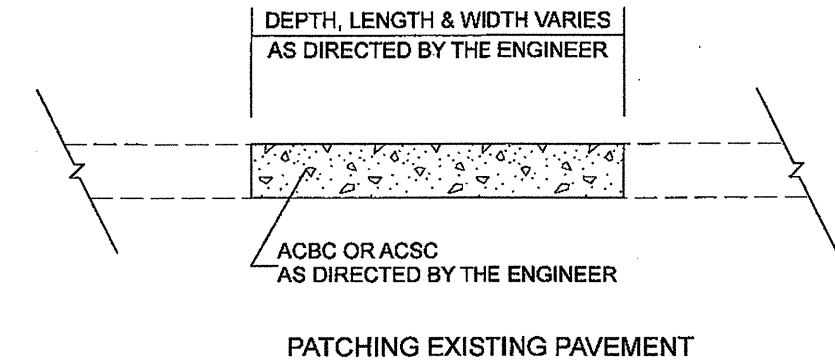

TYPICAL SECTION NO. 2

PAVEMENT SCHEDULE	
C1	PROP. APPROX. 1-1/2" ASPHALT CONC SURFACE COURSE, TYPE S9.5B, AT AN AVERAGE RATE OF 168 LBS. PER SQ. YD.
C2	PROP. APPROX. 1-1/2" ASPHALT CONC SURFACE COURSE, TYPE SF9.5A, AT AN AVERAGE RATE OF 165 LBS. PER SQ. YD.
T1	SHOULDER RECONSTRUCTION
V1	MILLING ASPHALT PAVEMENT, 0 TO 1-1/2" DEPTH
V2	MILLING ASPHALT PAVEMENT, 1-1/2" DEPTH

PROJECT NO.	SHEET NO.	TOTAL SHEETS
13CR.10611.13, 13CR.20611.11	5	

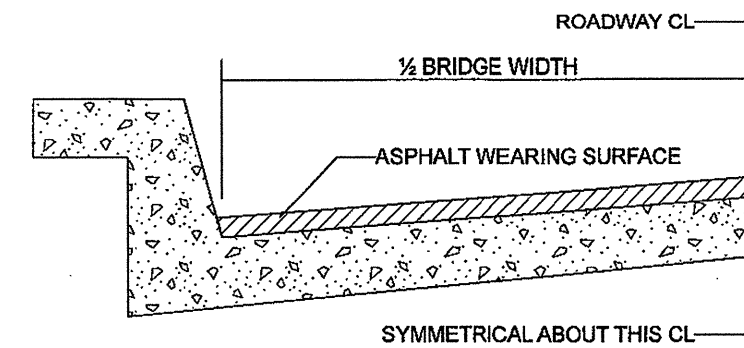
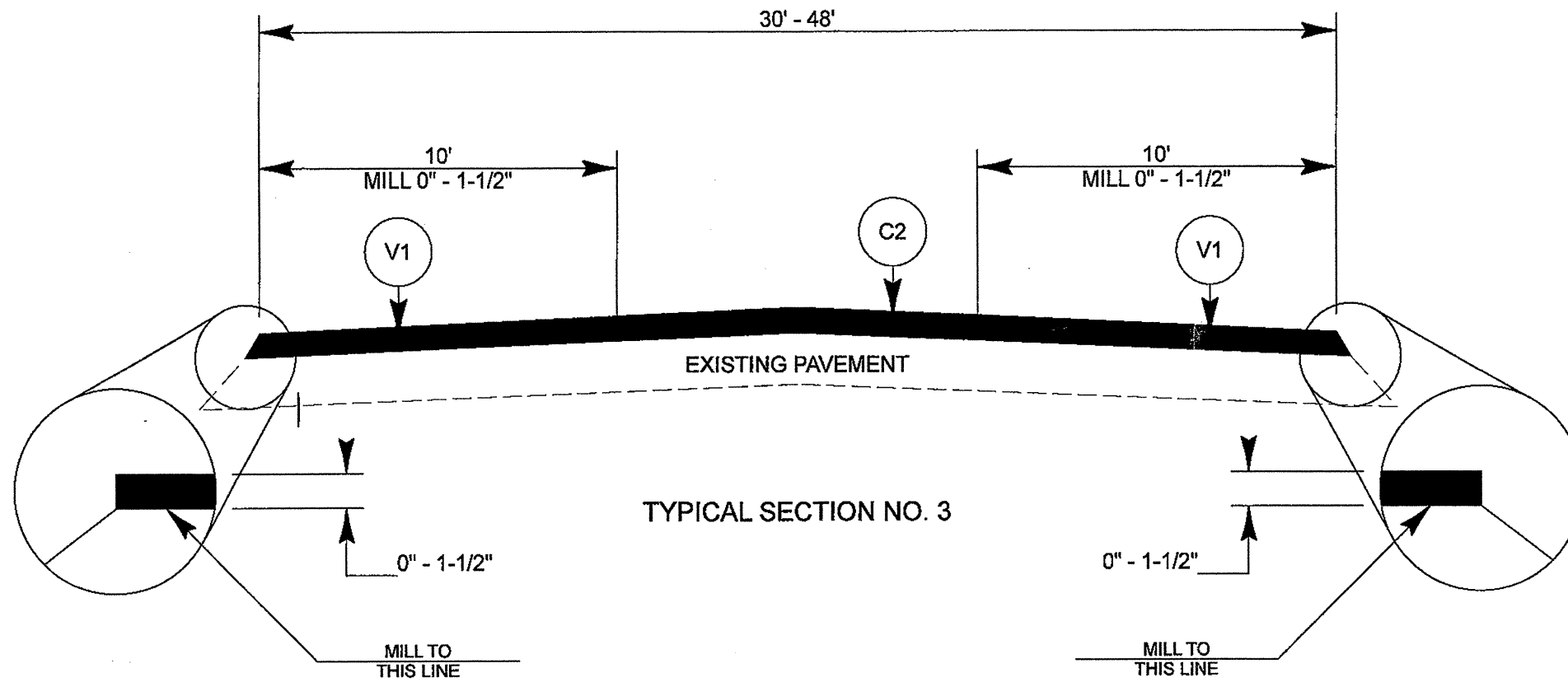

BRIDGE HALF TYPICAL SECTION

FOR BRIDGES WITH FLOOR DRAINS, CARE SHALL BE EXERCISED IN PLACING THE WEARING SURFACE AROUND FLOOR DRAINS SO AS NOT TO HINDER EFFECTIVE DRAINAGE. ALL DRAINS SHALL BE LEFT OPEN

THE PROPOSED WEARING SURFACE SHALL VARY IN THICKNESS AS NECESSARY TO PROVIDE A SMOOTH RIDING SURFACE. THE MINIMUM THICKNESS SHOULD DEPEND ON PAVEMENT TYPE AS FOLLOWS: S4.75A 1/2", SF9.5A 1.0", S9.5X 1.5", S12.5X 2.0", ULTRATHIN HOT MIX ASPHALT-TYPE A 3/4", ULTRATHIN HOT MIX ASPHALT-TYPE B 5/8", ULTRATHIN HOT MIX ASPHALT-TYPE C 1/2". THE MAXIMUM THICKNESS SHOULD DEPEND ON PAVEMENT TYPE AS FOLLOWS: S4.75A 1.0", SF9.5A 1.5", S9.5X 2.0", S12.5X 2.0", ULTRATHIN HOT MIX ASPHALT-TYPE A 3/4", ULTRATHIN HOT MIX ASPHALT-TYPE B 5/8", ULTRATHIN HOT MIX ASPHALT-TYPE C 1/2".

NOTES

ALL UNPAVED ROADS TO BE RESURFACED 50' FROM EDGE OF PAVEMENT OF MAIN PROJECT. ALL PAVED S.R. ROADS TO BE RESURFACED TO THE ENDS OF THE RADII, OR AS DIRECTED BY THE ENGINEER. EDGES, PAVEMENT WIDENING, INTERSECTIONS AND BRIDGE FLARES ARE INCLUDED IN THE TABLE OF QUANTITIES. SHOULDERS AND DITCHES ARE TO BE CONSTRUCTED BY OTHERS UNLESS OTHERWISE INDICATED. BRIDGES ARE TO BE RESURFACED AT LOCATIONS AND TO DEPTH AS DIRECTED BY THE ENGINEER.

PROJECT NO.	SHEET NO.	TOTAL SHEETS
13CR.10611.13, 13CR.20611.11	6	

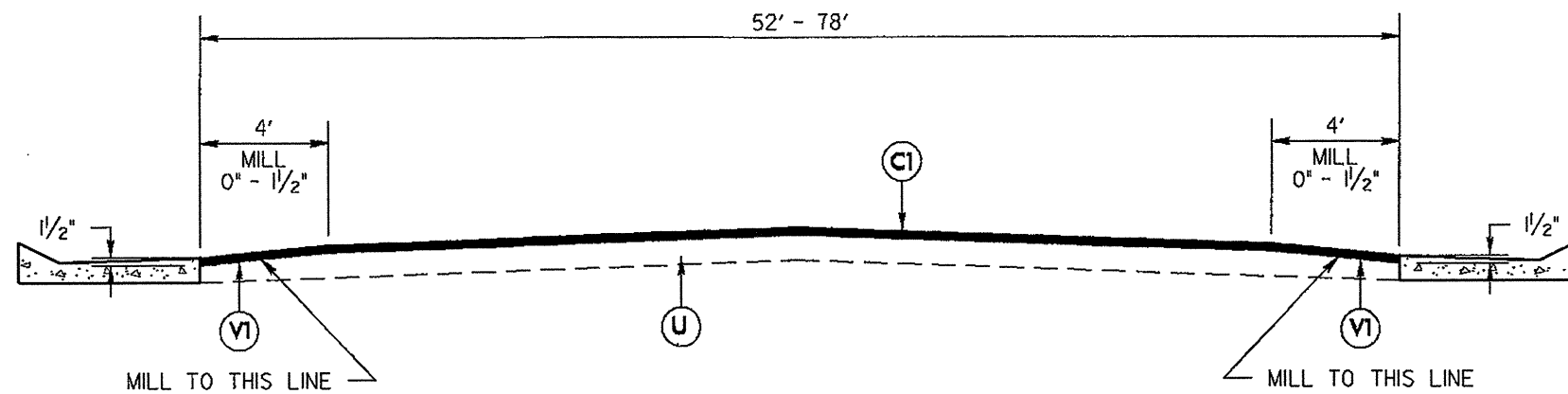

TYPICAL SECTION NO. 4

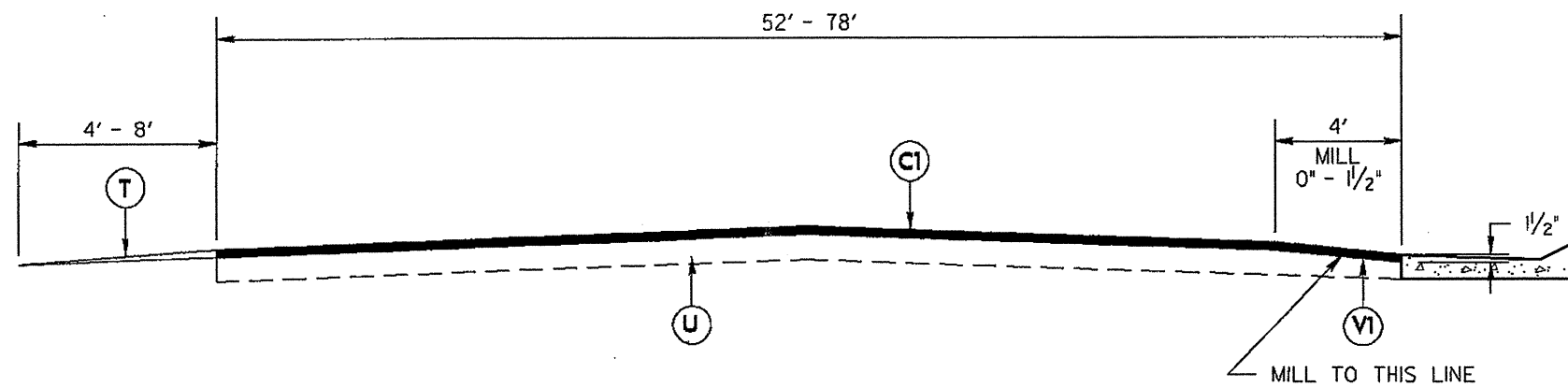

TYPICAL SECTION NO. 5

PAVEMENT SCHEDULE	
C1	PROP. APPROX. 1 1/2" ASPHALT CONCRETE SURFACE COURSE, TYPE 99.5B, AT AN AVERAGE RATE OF 168 LBS. PER SQ. YARD
T	SHOULDER RECONSTRUCTION
U	EXISTING PAVEMENT
V1	MILLING ASPHALT PAVEMENT, 0" TO 1 1/2" DEPTH

PROJECT NO.	SHEET NO.	TOTAL SHEETS
13CR.10611.13, 13CR.20611.11	7	

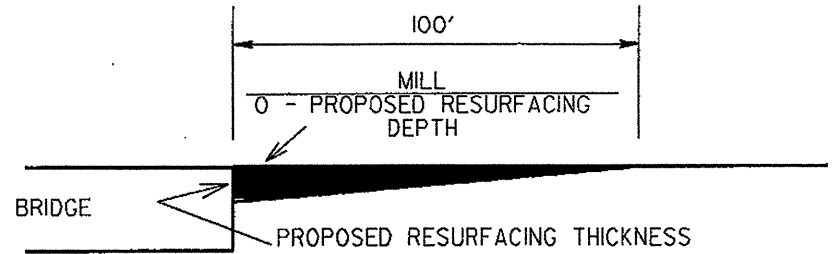

INCIDENTAL MILLING DETAIL AT BRIDGE APPROACHES
WHERE BRIDGES WILL NOT BE RESURFACED
COST OF BRIDGE APPROACH MILLING IS INCIDENTAL TO OTHER ITEMS

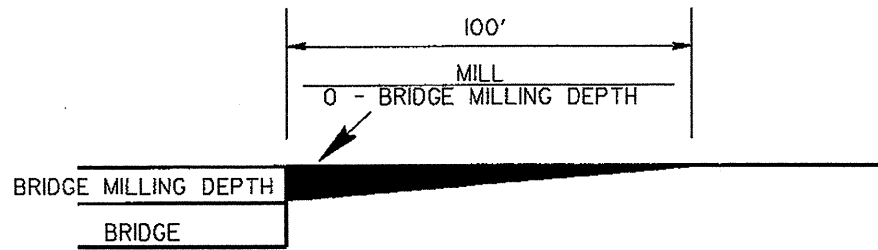

INCIDENTAL MILLING DETAIL AT BRIDGE APPROACHES
WHERE BRIDGES WILL BE MILLED THEN RESURFACED
COST OF BRIDGE APPROACH MILLING IS INCIDENTAL TO OTHER ITEMS

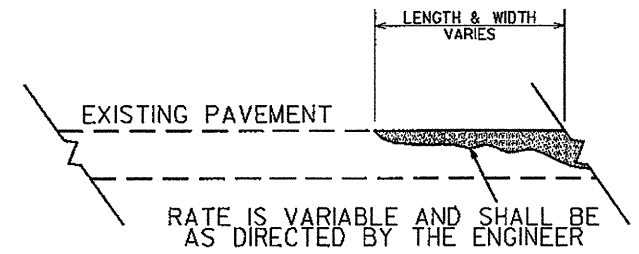
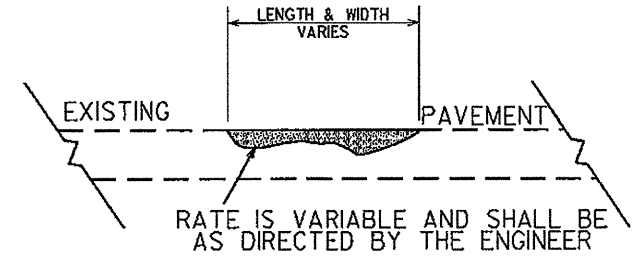

DETAIL SHOWING METHOD OF WEDGING

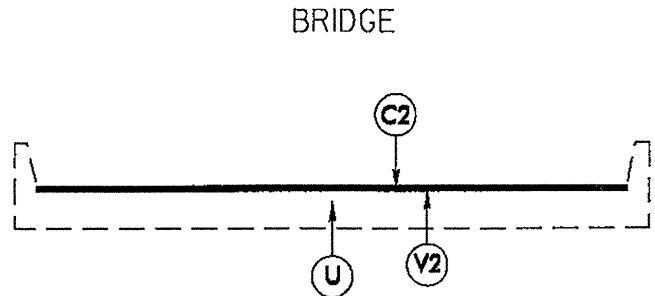

BRIDGE DETAIL

BRIDGE #45, #46, AND #128 ON MAP 12
MILL 1½" OF EXISTING PAVEMENT
SEE MAPS FOR BRIDGE LOCATION

PAVEMENT SCHEDULE	
C2	PROP. APPROX. 1½" ASPHALT CONCRETE SURFACE COURSE, TYPE SF9.5A, AT AN AVERAGE RATE OF 165 LBS. PER SQ. YARD
U	EXISTING PAVEMENT
V2	MILLING ASPHALT PAVEMENT, 1½" DEPTH

PROJECT REFERENCE NO.	SHEET NO.
13CR.10611.13, ETC	8

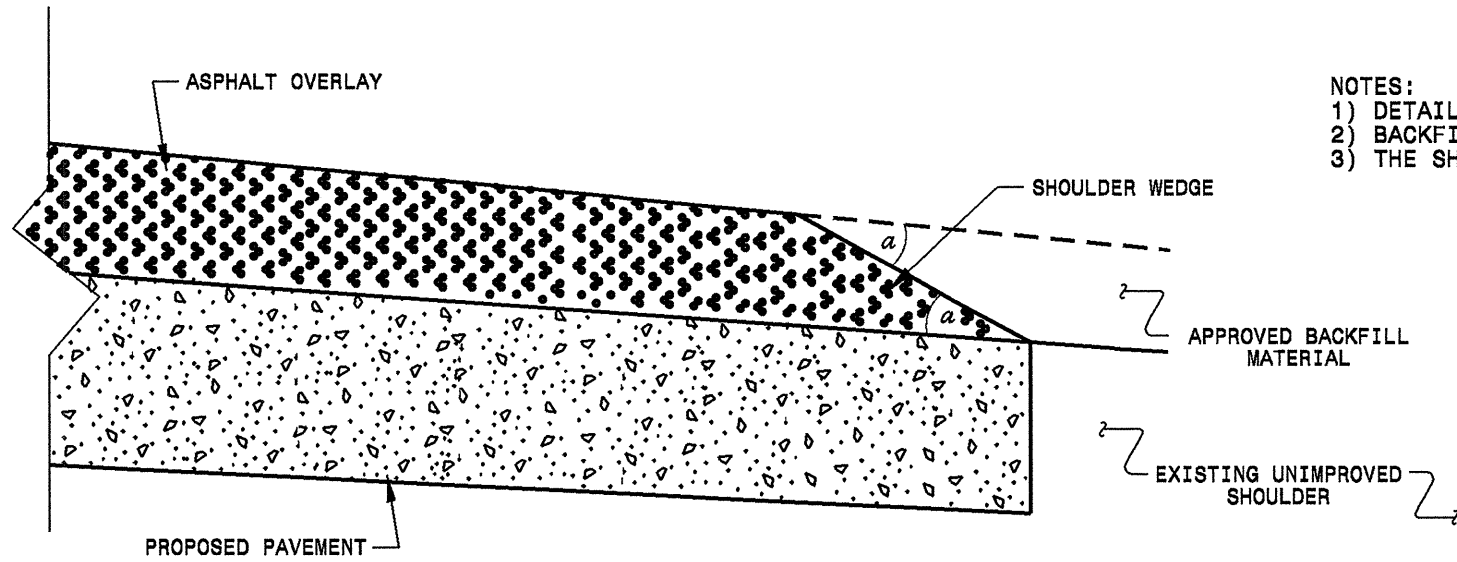

- NOTES:
 1) DETAIL DOES NOT APPLY TO OGAFB AND ULTRA-THIN BONDED WEARING COURSE.
 2) BACKFILL SHOULDER WITH APPROVED MATERIAL.
 3) THE SHOULDER WEDGE DEVICE MAY BE DISENGAGED AT PAVED DRIVEWAYS AND SIDE STREETS.

SHOULDER WEDGE DETAIL
 (Resurfacing Projects w/ Widening or
 with Existing Paved Shoulder having no dropoffs)

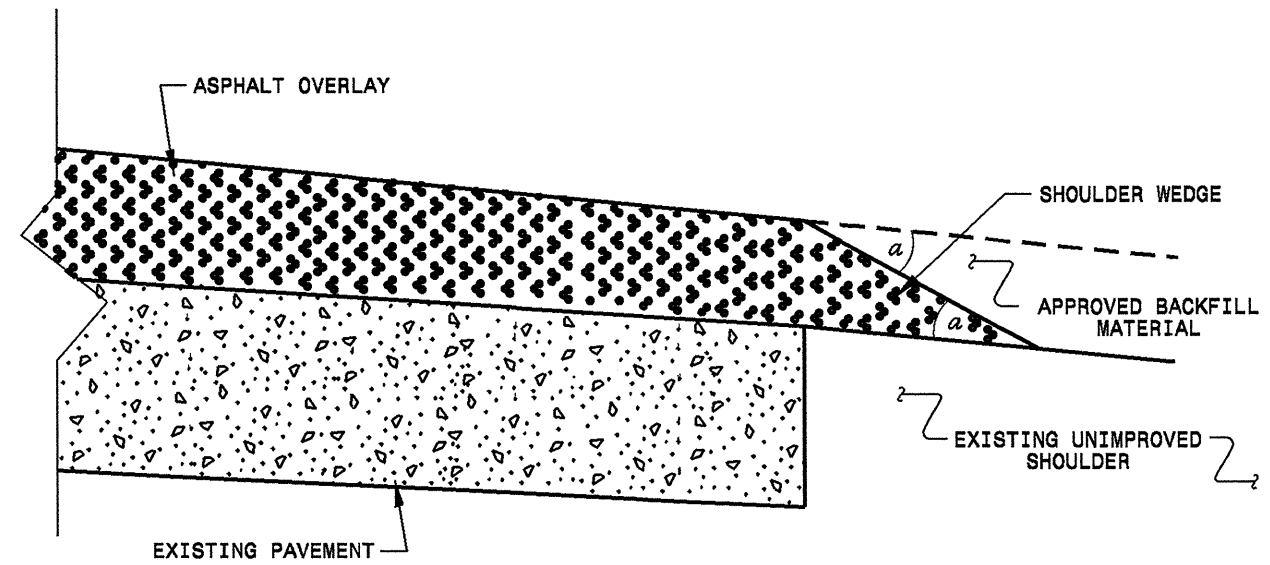

SHOULDER WEDGE DETAIL
 (Resurfacing Projects w/ NO Widening)

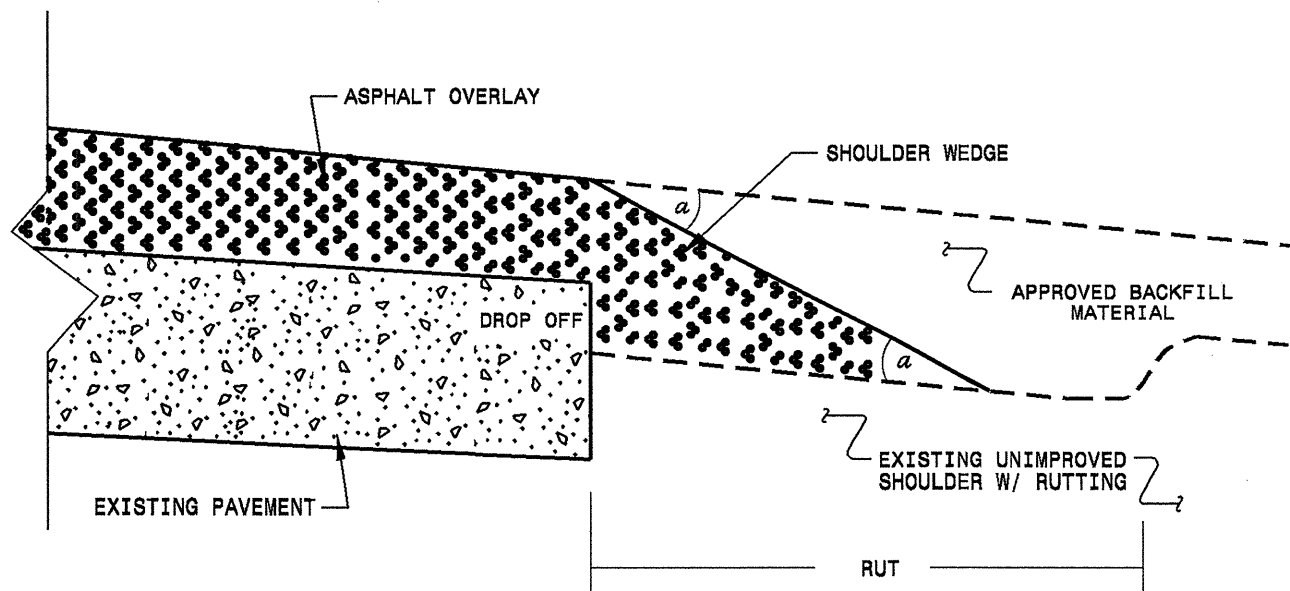

SHOULDER WEDGE DETAIL
 (Resurfacing Adjacent to
 Rutted Shoulder)

- SHOULDER WEDGE ANGLE = 30°

CONTRACT STANDARDS AND DEVELOPMENT UNIT		
Office 919-707-8980 FAX 919-280-4119		
SHOULDER WEDGE DETAILS		
ORIGINAL BY: T. SPELL	DATE: 7-18-11	
MODIFIED BY:	DATE: 10/16/12	
CHECKED BY:	DATE:	
FILE SPEC.: M:\www\details\stand\shoulderwedgedetail.dgn		

21-NOV-2013 11:26
 C:\Users\p.j.piper\Documents\miso\version\control\REVISED Shoulder Wedge Detail.dgn
 p.j.piper AT C06261888

5/14/99

22-MAR-2012 15:05 C:\Users\jhowerton\Documents\Standard Drawings\2012 Standard Drawings\2012 Curb Ramp Special Details\Curb Ramp Details.dgn jhowerton AT CS0237581

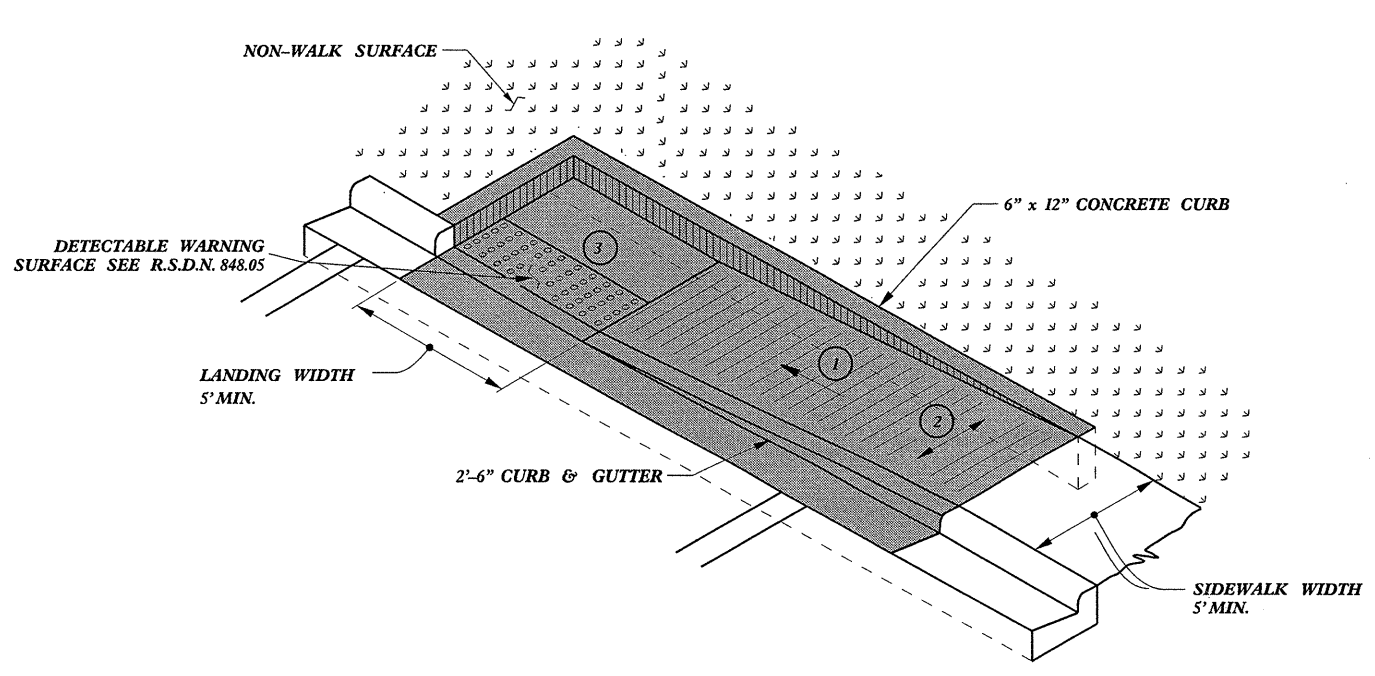

PAY LIMITS FOR CURB RAMP

TYPE 1A

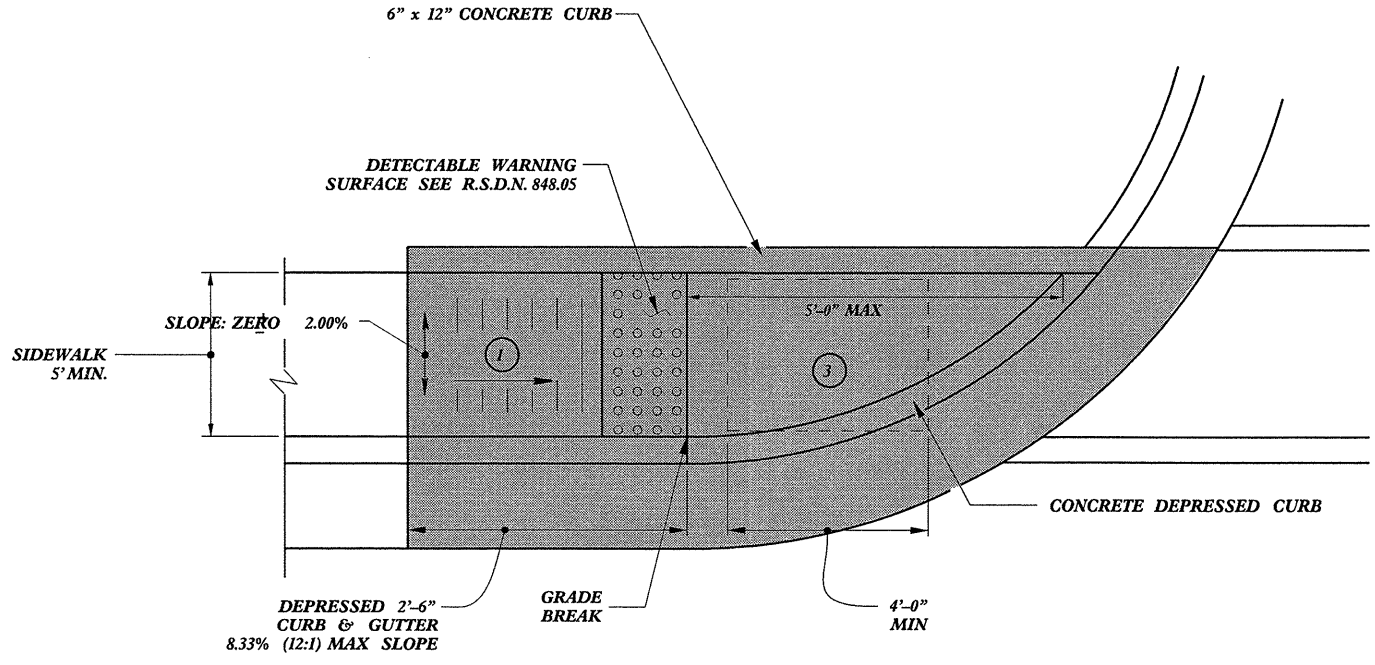

TYPE 1

- ① 8.33% (12:1) MAX RAMP SLOPE
- ② CROSS SLOPE: 2.00%
- ③ CURB RAMPS REQUIRE A (4'-0") MINIMUM LANDING WITH A MAXIMUM CROSS SLOPE AND LONGITUDINAL SLOPE OF 2.00% WHERE PEDESTRIANS PERFORM TURNING MANEUVERS. SLOPE TO DRAIN TO CURB.

REFER TO ROADWAY STANDARD DRAWING NUMBER 848.05 SHEET 3 OF 3 FOR ALL RAMP NOTES

CONTRACT STANDARDS AND DEVELOPMENT UNIT	
Office 919-707-6950 FAX 919-250-4119	
CURB RAMPS	
Directional Ramps	
ORIGINAL BY: J.S. HOWERTON	DATE: 7/7/11
MODIFIED BY:	DATE:
CHECKED BY:	DATE:
FILE SPEC: stds/2012CurbRamp/CurbRampDetails.dgn	

- 1 8.33% (12:1) MAX RAMP SLOPE
- 2 CROSS SLOPE: 2.00%
- 4 8.00% MAX CHANGE IN GRADE BETWEEN ROAD SURFACE AND DRIVEWAY

 PAY LIMITS FOR 1 CURB RAMP

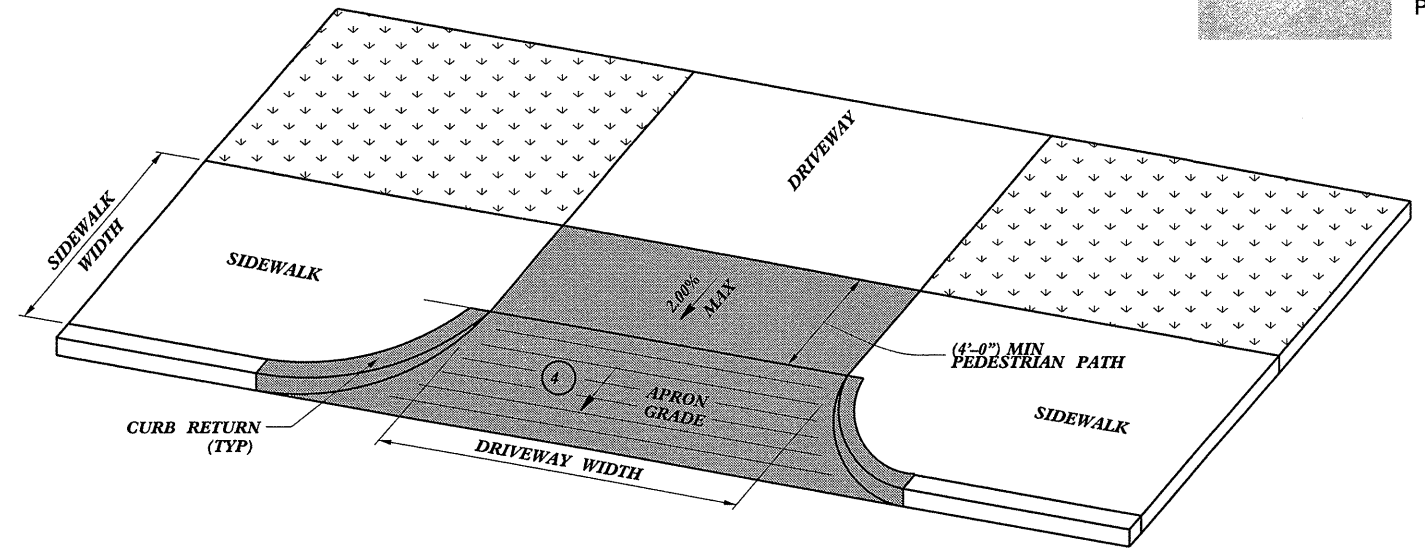

**DRIVEWAY APRON
OPTION 1**

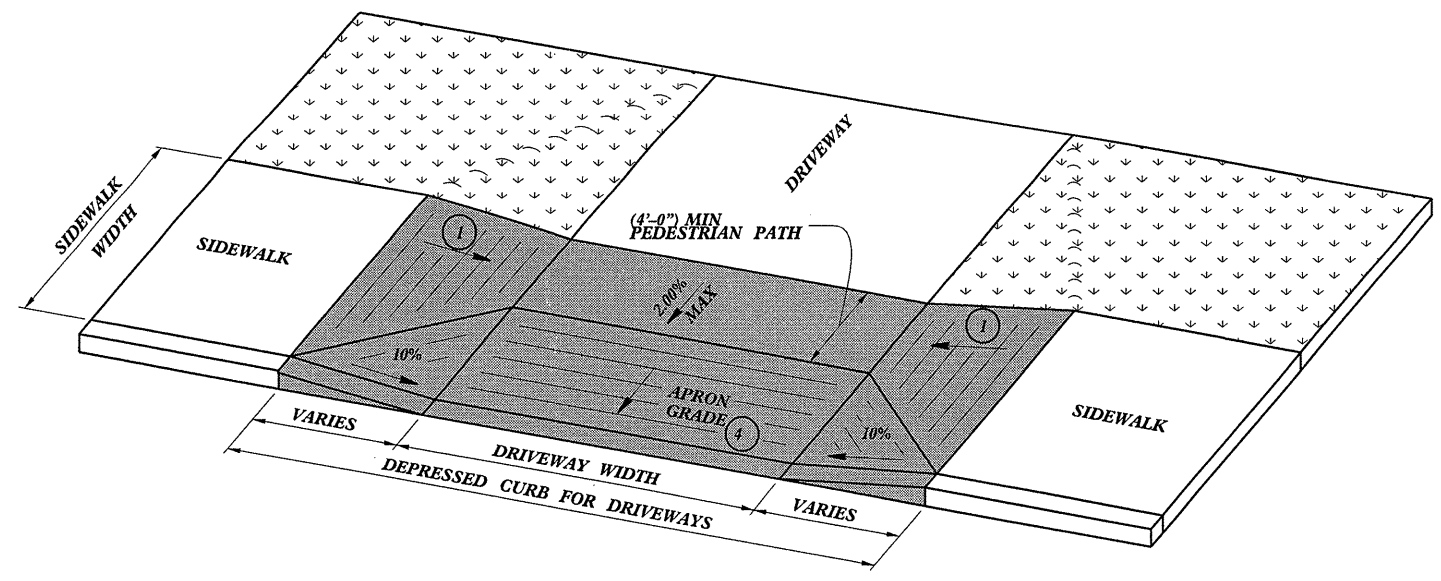

**DRIVEWAY APRON
OPTION 2**

-SEE ROADWAY DETAIL DRAWING 848.05 FOR DETECTABLE WARNING SURFACE AND FOR RAMP NOTES.
-SEE ROADWAY STANDARD DRAWING 848.02 FOR CONCRETE DRIVEWAYS.

CONTRACT STANDARDS AND DEVELOPMENT UNIT	
Office 919-707-6950 FAX 919-250-4119	
CURB RAMPS @ DRIVEWAY OPENINGS	
ORIGINAL BY: J.S. HOWERTON	DATE: 7/7/11
MODIFIED BY:	DATE:
CHECKED BY:	DATE:
FILE SPEC: stds/2012CurbRamp/CurbRampDetails.dwg	

5/14/09
SYTIME
C:\P\2012\848.02\848.02.dwg
USER: JSH

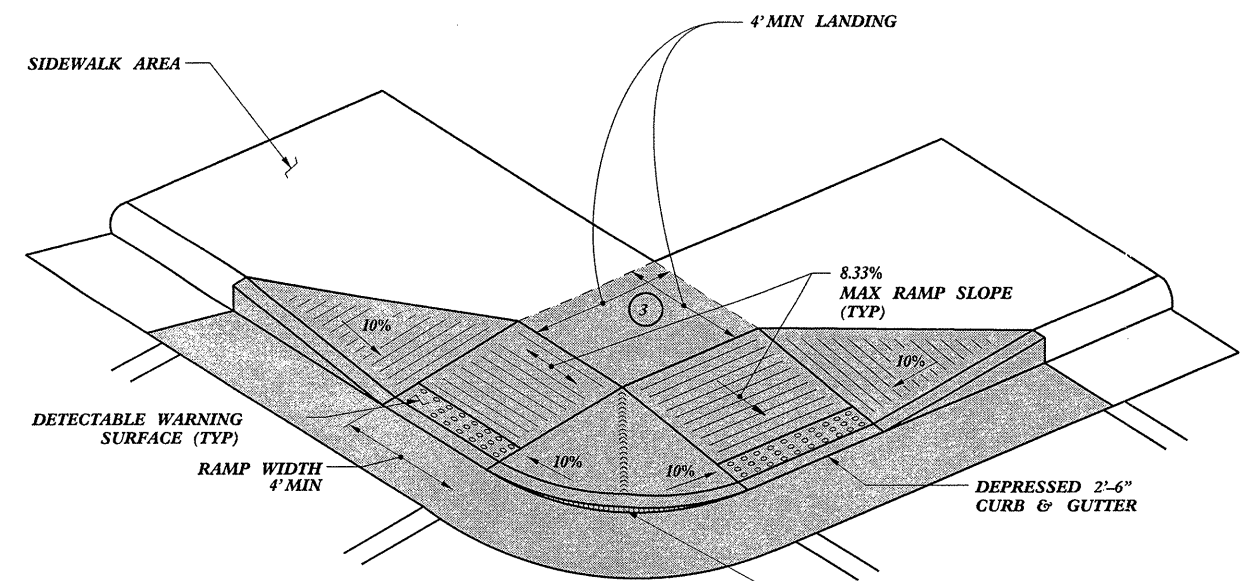

TYPE 4

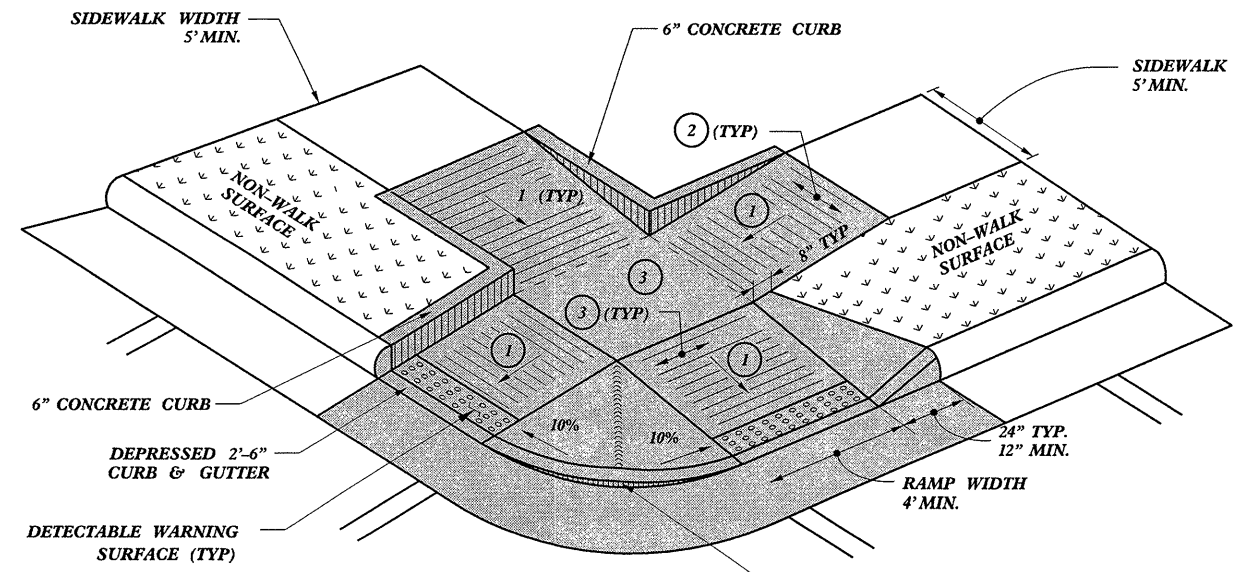

TYPE 5

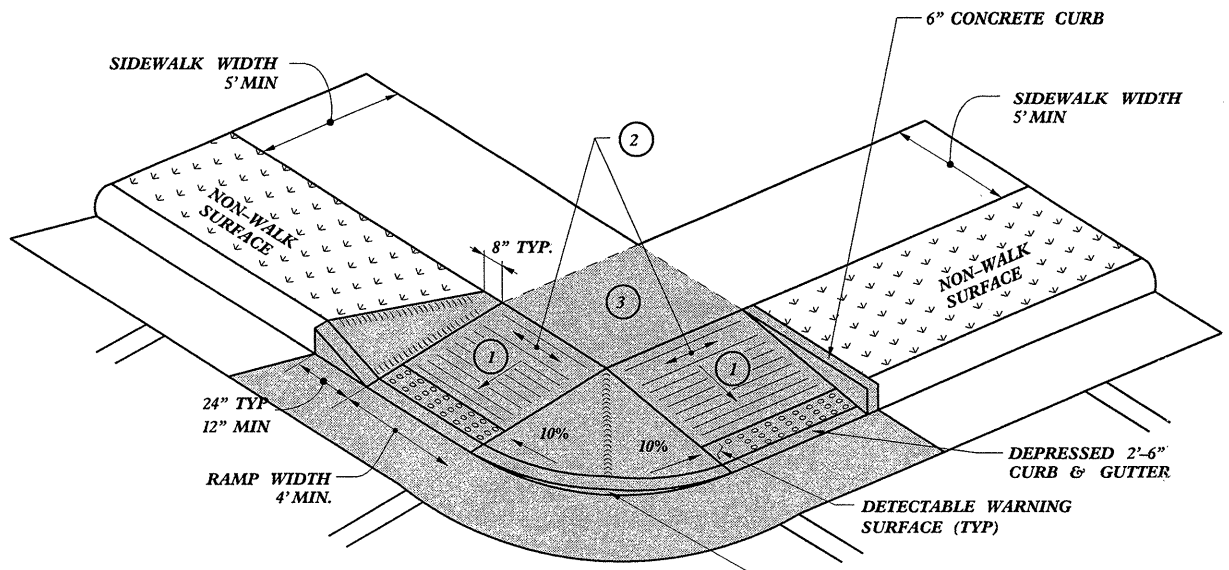

TYPE 4A

PAY LIMITS FOR CURB RAMP

- 1 8.33% (12:1) MAX RAMP SLOPE
- 2 CROSS SLOPE: 2.00%
- 3 CURB RAMPS REQUIRE A (4'-0") MINIMUM LANDING WITH A MAXIMUM CROSS SLOPE AND LONGITUDINAL SLOPE OF 2.00% WHERE PEDESTRIANS PERFORM TURNING MANEUVERS. SLOPE TO DRAIN TO CURB.

CONTRACT STANDARDS AND DEVELOPMENT UNIT	
Office 919-707-6950 FAX 919-250-4119	
CURB RAMPS	
Shared Landing	
ORIGINAL BY: J.S. HOWERTON	DATE: 7/7/11
MODIFIED BY:	DATE:
CHECKED BY:	DATE:
FILE SPEC: stds/2012CurbRamp/CurbRampDetails.dwg	

REFER TO ROADWAY STANDARD DRAWING NUMBER 848.05 SHEET 3 OF 3 FOR ALL RAMP NOTES

5/14/09
22-MAR-2012 15:08
S:\Contractors\Special Details\Howerton\Standard Drawings\2012 Curb Ramp Special Details\Curb Ramp Details.dgn
J.Howerton AT 150237501

5/14/99
32-MAR-2012 15:07
S:\Contracts\Standard Drawings\2012 Standard Drawings\2012 Curb Ramp Special Details\Curb Ramp Details.dgn
J.Howerton AT CSD237581

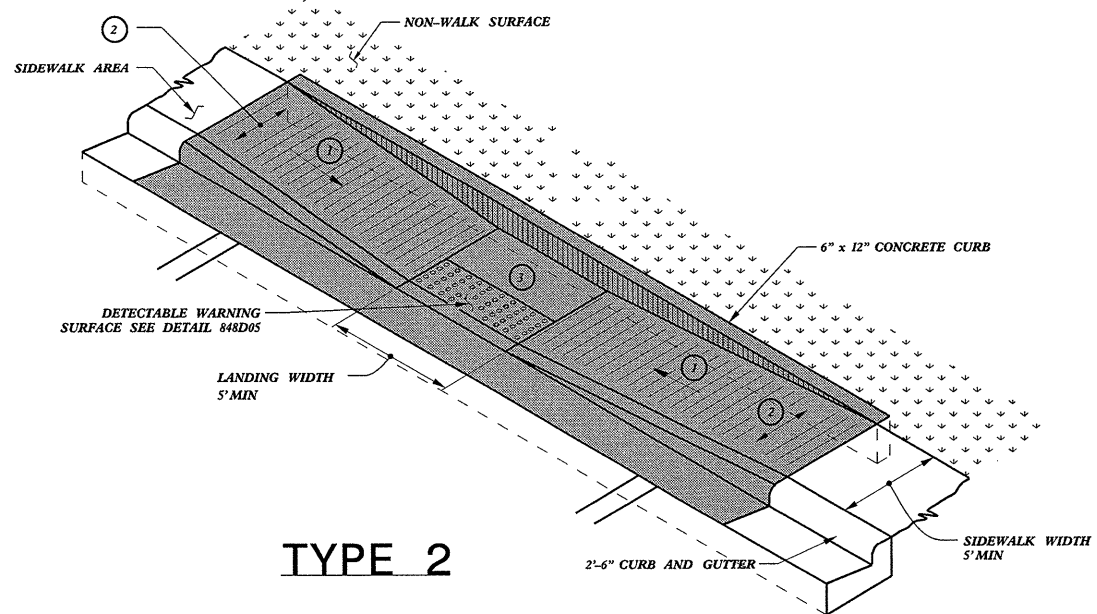

TYPE 2

PAY LIMITS FOR CURB RAMP

- ① 8.33% (12:1) MAX RAMP SLOPE
- ② CROSS SLOPE: 2.00%
- ③ CURB RAMPS REQUIRE A (4'-0") MINIMUM LANDING WITH A MAXIMUM CROSS SLOPE AND LONGITUDINAL SLOPE OF 2.00% WHERE PEDESTRIANS PERFORM TURNING MANEUVERS. SLOPE TO DRAIN TO CURB.

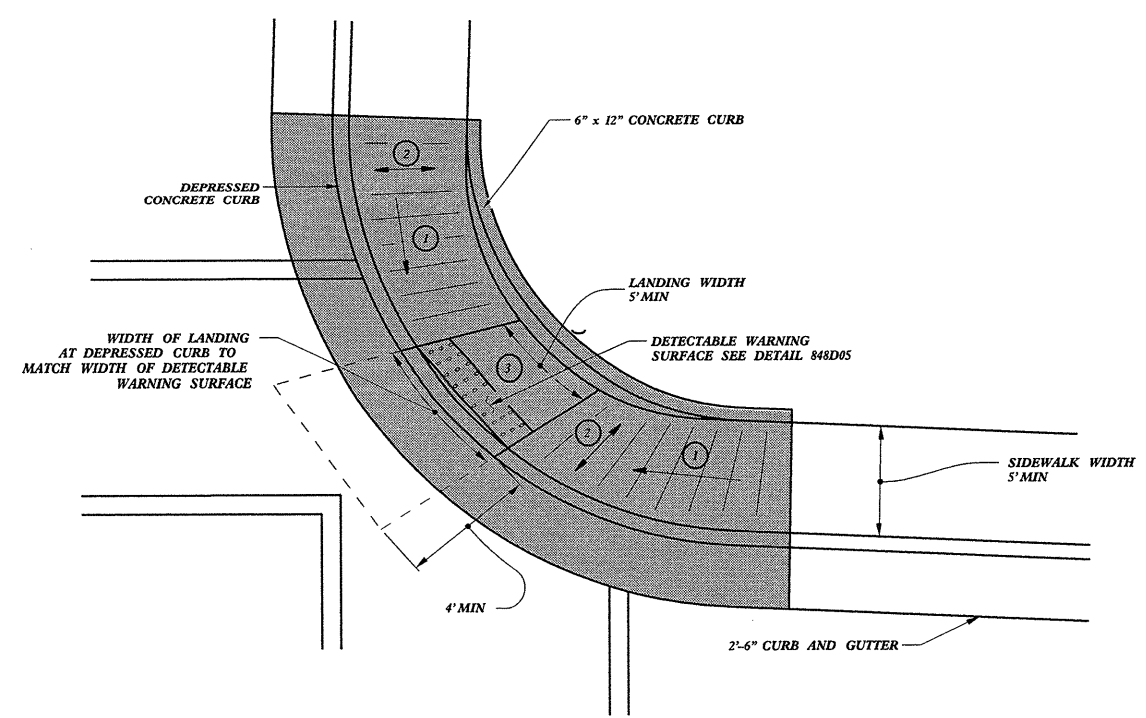

TYPE 2A

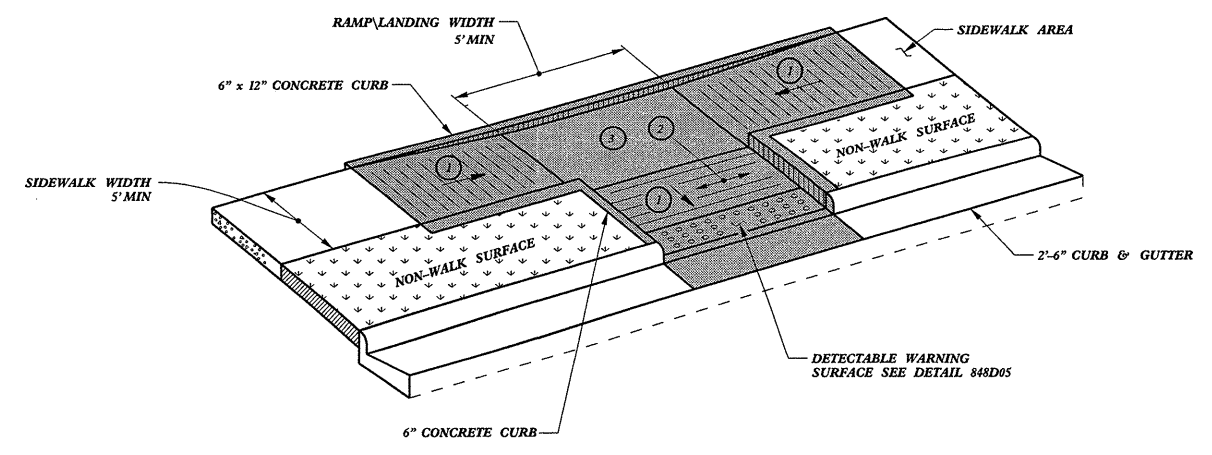

TYPE 3

REFER TO ROADWAY STANDARD DRAWING NUMBER 848.05 SHEET 3 OF 3 FOR ALL RAMP NOTES

CONTRACT STANDARDS AND DEVELOPMENT UNIT	
Office 919-707-6950 FAX 919-250-4119	
CURB RAMPS	
Parallel Ramps	
ORIGINAL BY: J.S. HOWERTON	DATE: 7/7/11
MODIFIED BY:	DATE:
CHECKED BY:	DATE:
FILE SPEC: stds/2012CurbRamp/CurbRampDetails.dgn	

SUMMARY OF QUANTITIES

PROJECT NO	COUNTY	MAP NO	ROUTE	DESCRIPTION	TYP NO	FINAL SURFACE TESTING REQUIRED	WARM MIX ASPHALT REQUIRED	LENGTH MI	WIDTH FT	INCIDENTAL STONE BASE TON	SHOULDER RECONSTRUCTION SMI	MILLING ASPHALT PAVEMENT, 1-1/2" DEPTH SY	MILLING ASPHALT PAVEMENT, 0" TO 1 1/2" DEPTH SY	ASPHALT CONC SURFACE COURSE, TYPE S9.5B TON	ASPHALT CONC SURFACE COURSE, TYPE SF9.5A TON	ASPHALT BINDER FOR PLANT MIX TON	PATCHING EXISTING PAVEMENT TON	CONCRETE CURB RAMP (std. 848.05/ etc) EA	ADJUSTMENT OF MANHOLES EA	ADJUSTMENT OF METER BOXES OR VALVE BOXES EA	4413000000-E	4457000000-N	4510000000-N		
																					WORK ZONE ADVANCE/ GENERAL WARNING SIGNING SF	TEMPORARY TRAFFIC CONTROL LS	LAW ENFORCEMENT HR		
13CR.10611.13	Mitchell	1	NC 226	FROM SOUTH END OF 1250 TO THREE LANE SECTION (MP 10.35 - MP 7.25)	1	NO	NO	3.1	32 - 44	155	6.20		4,978	5,566		334	1,100				122	*	40		
			2	NC 226	FROM BEG. THREE LANE SECTION TO SR 1403 (MP 7.25 - MP 6.71)	1,4,5	NO	NO	0.54	52	27	0.72		1,423	1,874		112	150					100	20	
			3	NC 197	FROM NC 226 TO PAVEMENT CHANGE (MP 0.73 - MP 1.36)	1	NO	NO	0.63	18	32	1.26		600	619		37	650					100	20	
			4	NC 197	FROM PAVEMENT CHANGE TO UNIMIN PLANT RD (MP 1.36 - MP 2.03)	1	NO	NO	0.67	22 - 48	34	1.34		734	935		56	450		1				100	20
			5	NC 226	FROM SR 1403 TO UNIMIN DRIVE (MP 6.71 - MP 6.48)	1,4,5	NO	NO	0.23	78	12	0.20		4,455	1,194		72	200						100	20
TOTAL FOR PROJ NO. 13CR.10611.13							5.17		260	9.72		12,190	10,188		611	2,550		1		522	1	120			
13CR.20611.11	Mitchell	6	SR 1275	FROM US 19E TO PVMT WIDTH CHANGE (MP 0.72 - MP 0.36)	2	NO	NO	0.36	30	9					577	39	100		5	1	100	*	20		
			7	SR 1275	FROM PVMT WIDTH CHANGE TO SR 1403 (MP 0.36 - MP 0.00)	2,3	NO	NO	0.36	40			2,534		769	52	100	17		6	7		100	20	
			8	SR 1297	FROM BRIDGE NO. 9 TO END C&G (MP 0.42 - MP 0.49)	3	NO	NO	0.07	48			822		179	12	25						100	20	
			9	SR 1297	FROM END C&G TO BEGIN C&G (MP 0.49 - MP 0.74)	2	NO	NO	0.25	24	13				321	22	125						100	20	
			10	SR 1297	FROM BEGIN C&G TO SR 1403 (MP 0.74 - MP 0.84)	3	NO	NO	0.1	30			1,174		160	11	25	1					100	20	
			11	SR 1403	FROM US 19E TO BRIDGE NO. 8 (MP 2.39 - MP 1.99)	2,3	NO	NO	0.4	36	15			3,920		769	52	100	3		3			100	20
			12	SR 1211	FROM SR 1210 TO SR 1217 (MP 5.51 - MP 2.01)	2	NO	NO	3.5	18	175			470		3,377	226	900						122	40
TOTAL FOR PROJ NO. 13CR.20611.11							5.04		212		470	8,450	6,152	414	1,375	21	14	8	722	1	160				
GRAND TOTAL							10.21		472	9.72	470	20,640	10,188	6,152	1,025	3,925	21	15	8	1,244	1	280			

THERMOPLASTIC AND PAINT QUANTITIES

PROJECT NO	COUNTY	MAP NO	ROUTE	DESCRIPTION	TYP NO	LANES	LANE TYPE	LENGTH	WIDTH	4685000000-E	4686000000-E	4695000000-E	4710000000-E	4721000000-E	4725000000-E	4810000000-E	4905000000-N									
										THERMOPLASTIC PAVEMENT MARKING LINES (4", 90 MILS) WHITE LF	THERMOPLASTIC PAVEMENT MARKING LINES (4", 120 MILS) YELLOW LF	THERMOPLASTIC PAVEMENT MARKING LINES (4", 120 MILS) WHITE LF	THERMOPLASTIC PAVEMENT MARKING LINES (8", 90 MILS) YELLOW LF	THERMOPLASTIC PAVEMENT MARKING LINES (24", 120 MILS) WHITE LF	THERMOPLASTIC PAVEMENT MARKING CHARACTER (120 MILS) SCHOOL EA	THERMOPLASTIC PAVEMENT MARKING CHARACTER (120 MILS) ONLY EA	THERMOPLASTIC PAVEMENT MARKING SYMBOL (90 MILS) LT ARROW EA	THERMOPLASTIC PAVEMENT MARKING SYMBOL (90 MILS) RT ARROW EA	THERMOPLASTIC PAVEMENT MARKING SYMBOL (90 MILS) MERGE ARROW EA	THERMOPLASTIC PAVEMENT MARKING SYMBOL (90 MILS) STR ARROW EA	PAINT PAVEMENT MARKING LINES (4") WHITE LF	PAINT PAVEMENT MARKING LINES (4") YELLOW LF	SNOWPLOWABLE PAVEMENT MARKERS EA			
13CR.10611.13	Mitchell	1	NC 226	FROM SOUTH END OF 1250 TO THREE LANE SECTION (MP 10.35 - MP 7.25)	1	2	2WU	3.1	32 - 44	32,736	34,346		550	158	12	3	1							410		
			2	NC 226	FROM BEG. THREE LANE SECTION TO SR 1403 (MP 7.25 - MP 6.71)	1,4,5	4	MU	0.54	52	5,703	11,705	1,426	525			1	2	3						286	
			3	NC 197	FROM NC 226 TO PAVEMENT CHANGE (MP 0.73 - MP 1.36)	1	2	2WU	0.63	18	6,653	6,653														84
			4	NC 197	FROM PAVEMENT CHANGE TO UNIMIN PLANT RD (MP 1.36 - MP 2.03)	1	2	MU	0.67	22 - 48	7,075	7,075	300				4	2								89
			5	NC 226	FROM SR 1403 TO UNIMIN DRIVE (MP 6.71 - MP 6.48)	1,4,5	4	MU	0.23	78	2,429	2,429	600	150	75		2	1			4					122
TOTAL FOR PROJ NO. 13CR.10611.13							5.17		54,596	62,208	2,326	1,225	233	12	4	8	4	3	4					991		
13CR.20611.11	Mitchell	6	SR 1275	FROM US 19E TO PVMT WIDTH CHANGE (MP 0.72 - MP 0.36)	2	2	2WU	0.36	30				50			7	3					7,603	7,603			
			7	SR 1275	FROM PVMT WIDTH CHANGE TO SR 1403 (MP 0.36 - MP 0.00)	2,3	3	MU	0.36	40				275			4						1,000	8,000		
			8	SR 1297	FROM BRIDGE NO. 9 TO END C&G (MP 0.42 - MP 0.49)	3	2	2WU	0.07	48															1,478	
			9	SR 1297	FROM END C&G TO BEGIN C&G (MP 0.49 - MP 0.74)	2	2	2WU	0.25	24														5,280	5,280	
			10	SR 1297	FROM BEGIN C&G TO SR 1403 (MP 0.74 - MP 0.84)	3	3	MU	0.1	30					20			3						2,112	2,112	
			11	SR 1403	FROM US 19E TO BRIDGE NO. 8 (MP 2.39 - MP 1.99)	2,3	3	MU	0.4	36					50			11						8,448	10,000	
			12	SR 1211	FROM SR 1210 TO SR 1217 (MP 5.51 - MP 2.01)	2	2	2WU	3.5	18					155			25	3					73,920	73,920	
TOTAL FOR PROJ NO. 13CR.20611.11							5.04					550			25	3					98,363	108,393				
GRAND TOTAL							10.21		54,596	62,208	2,326	1,225	783	12	4	33	7	3	4		98,363	108,393	991			